

Outline of Communication System of TeikyoSat-4

March 10, 2017

Revised on June 15, 2017

**Space System Society
Teikyo University**

Overall System Diagram

Communication System Diagram (1)



Main Mission

New Mission

CW, AFSK

CW, AFSK, GMSK, SSTV

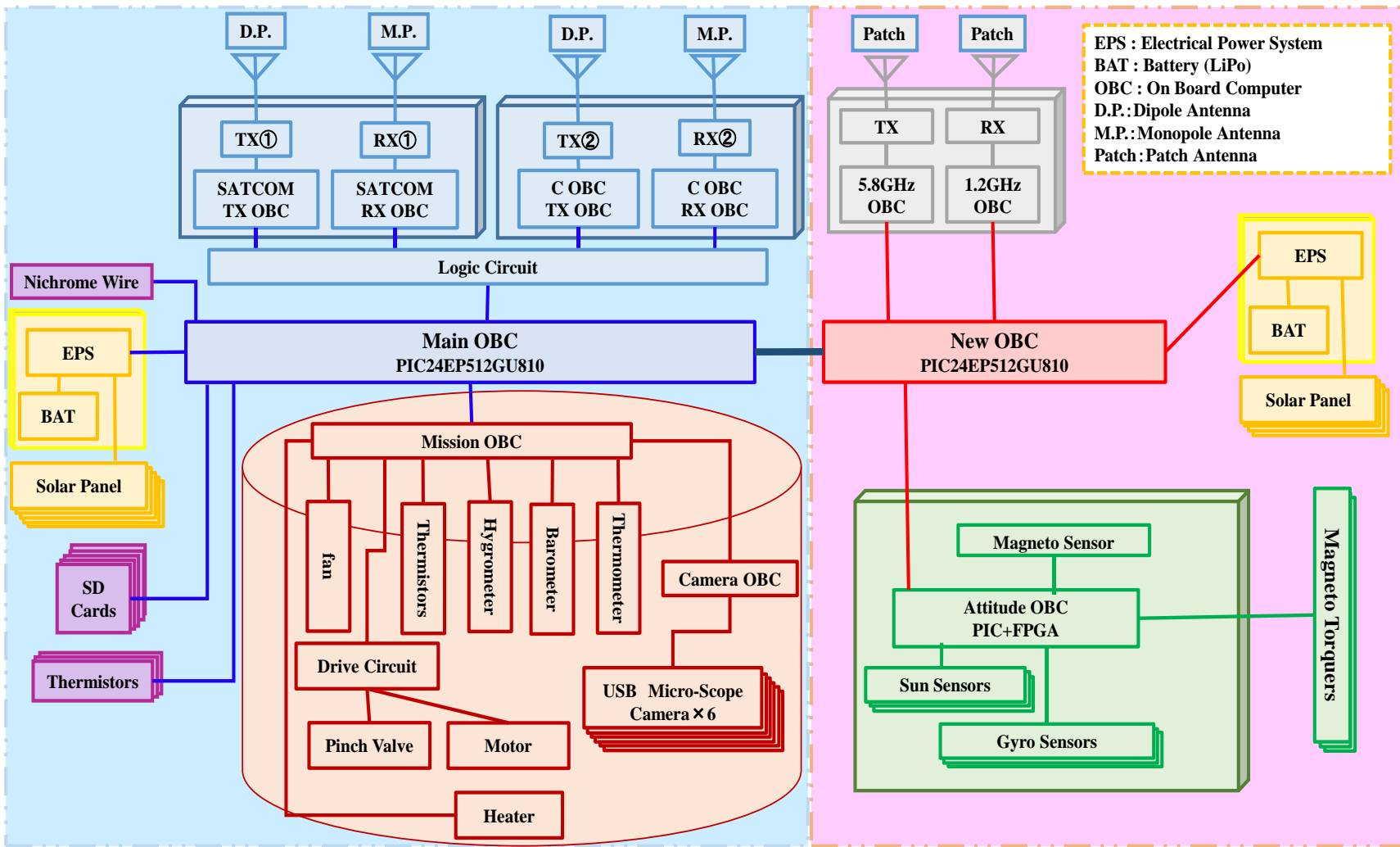

Communication System Diagram (2)

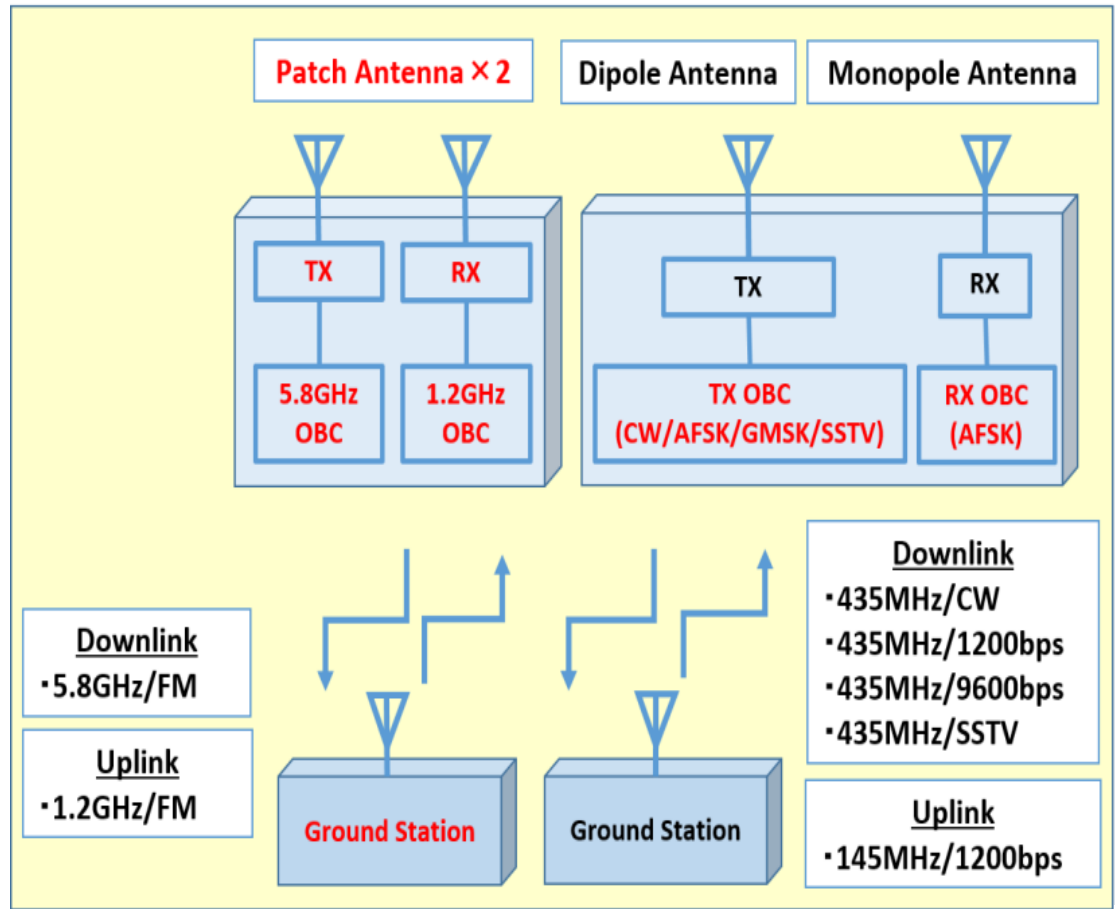

File type and data volume for downlink		
File Type	Image Style	[kB]
RAW Image	Thumbnail	40
	Default Size	200
JPEG Image	Thumbnail	20
	Default Size	100

Time taking for downlink to a RAW default image	
Communication Way	Time
435MHz/AFSK/1200bps/FM	1 week
435MHz/GMSK/9600bps/FM	3 minutes
435MHz/SSTV/FM	2 minutes
5.8GHz/FSK/115.2kbps	1 minute

SSTV: Slow Scan Television

System of Communication OBC



CW,AFSK
[Type of TeikyoSat-3]

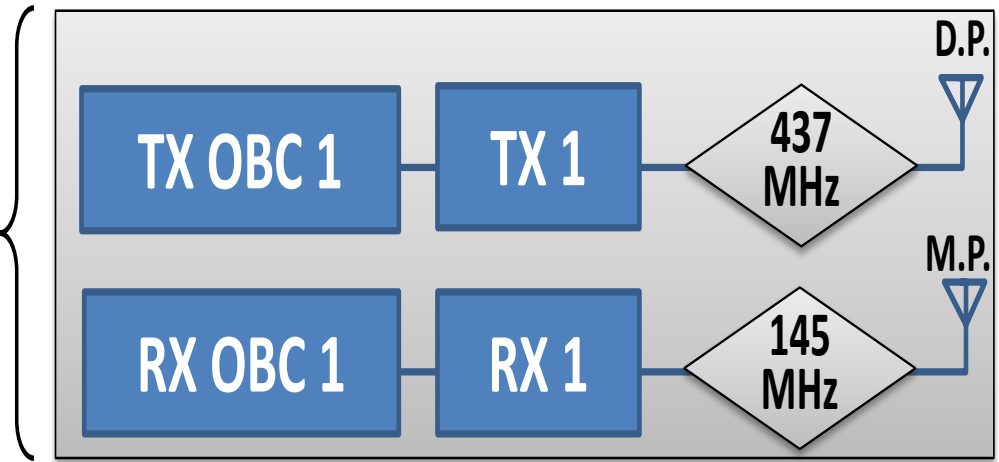

**CW,AFSK,
GMSK,SSTV**
[TeikyoSat-4 original]

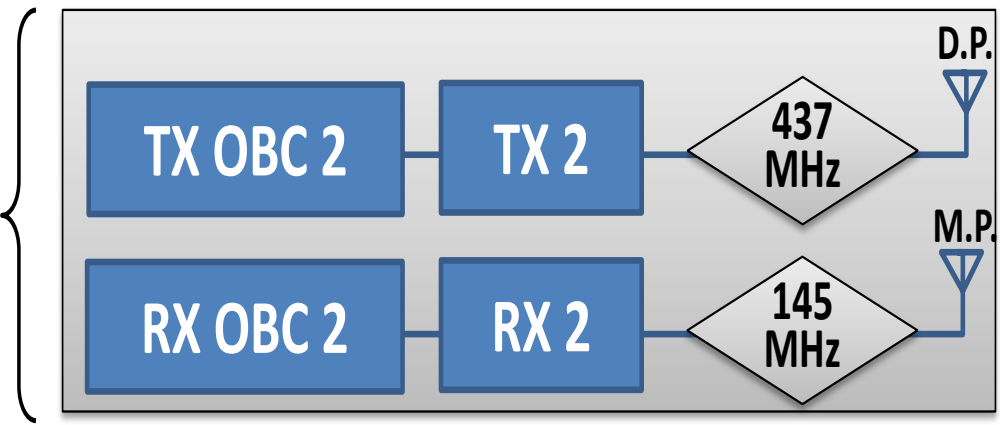

TeikyoSat-4 Communication System

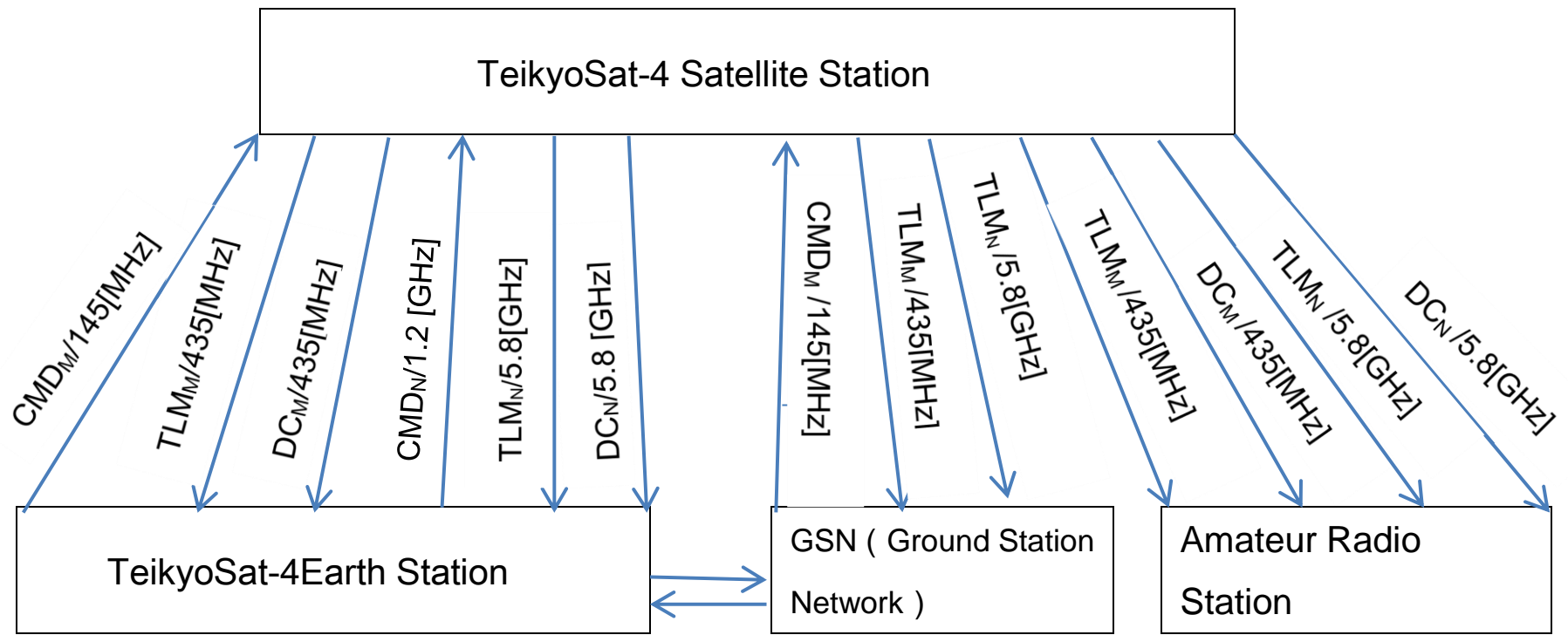

CMD_M : Command for Main Mission, 145MHz, CMD_N : Command for New Mission, 1.2GHz
 TLM_M : Telemetry at Main Mission, 435MHz, TLM_N : Telemetry at New Mission, 5,8GHz
 DC_M : Data Communication of Main Mission, 435 MHz,
 DC_N : Data Communication of New Mission, 5.8GHz

TeikyoSat-4 Antenna Mountings

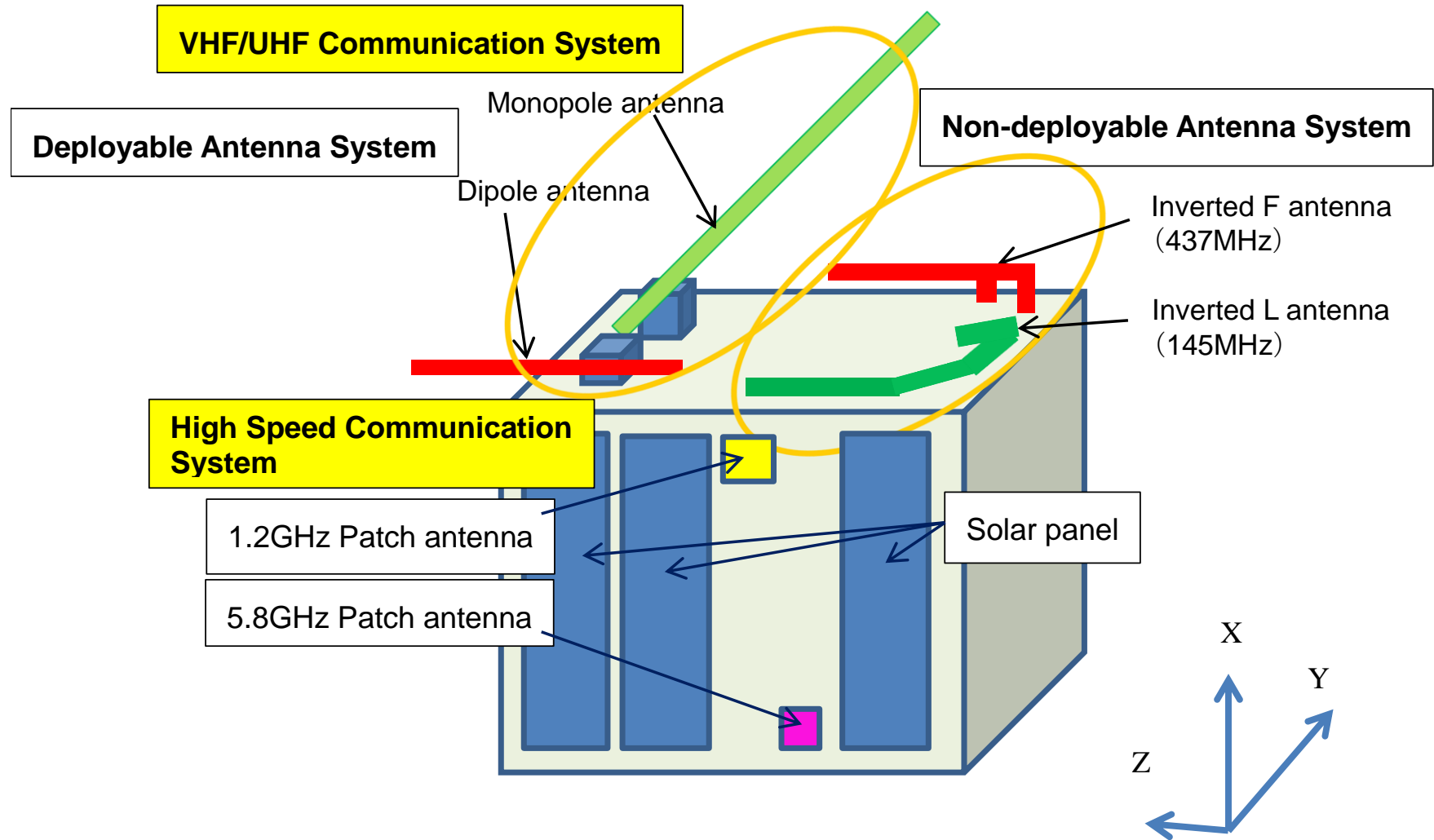

Main Mission (VHF/UHF System)

VHF/UHF Transmitter TXE430MFMCW-301A

Properties	Value
FM Transmitting Power [mW]	800
CW Transmitting Power [mW]	100
FM Transmitter Consumption Current [mA]	600
CW Transmitter Consumption Current [mA]	95
FM Transmitter Source Voltage [V]	5
CW Transmitter Source Voltage [V]	4.2
Operation Environment Temperature [deg C]	-30 ~ +60
Output Impedance [Ω]	50
Casing Dimensions [mm]	100×60×10.5
Mass [g]	60

VHF/UHF Receiver RXE145M-301A

Properties	Value
Receptive Sensitivity [dBm]	-123
Consumption Current [mA]	25
Source Voltage [V]	5
Operational Environment Temperature [deg C]	-30~+60
Casing Dimensions [mm]	60×50×10.5
Mass [g]	38

VHF/UHF Transmitter /Receiver (Nishi Musen, Inc.)

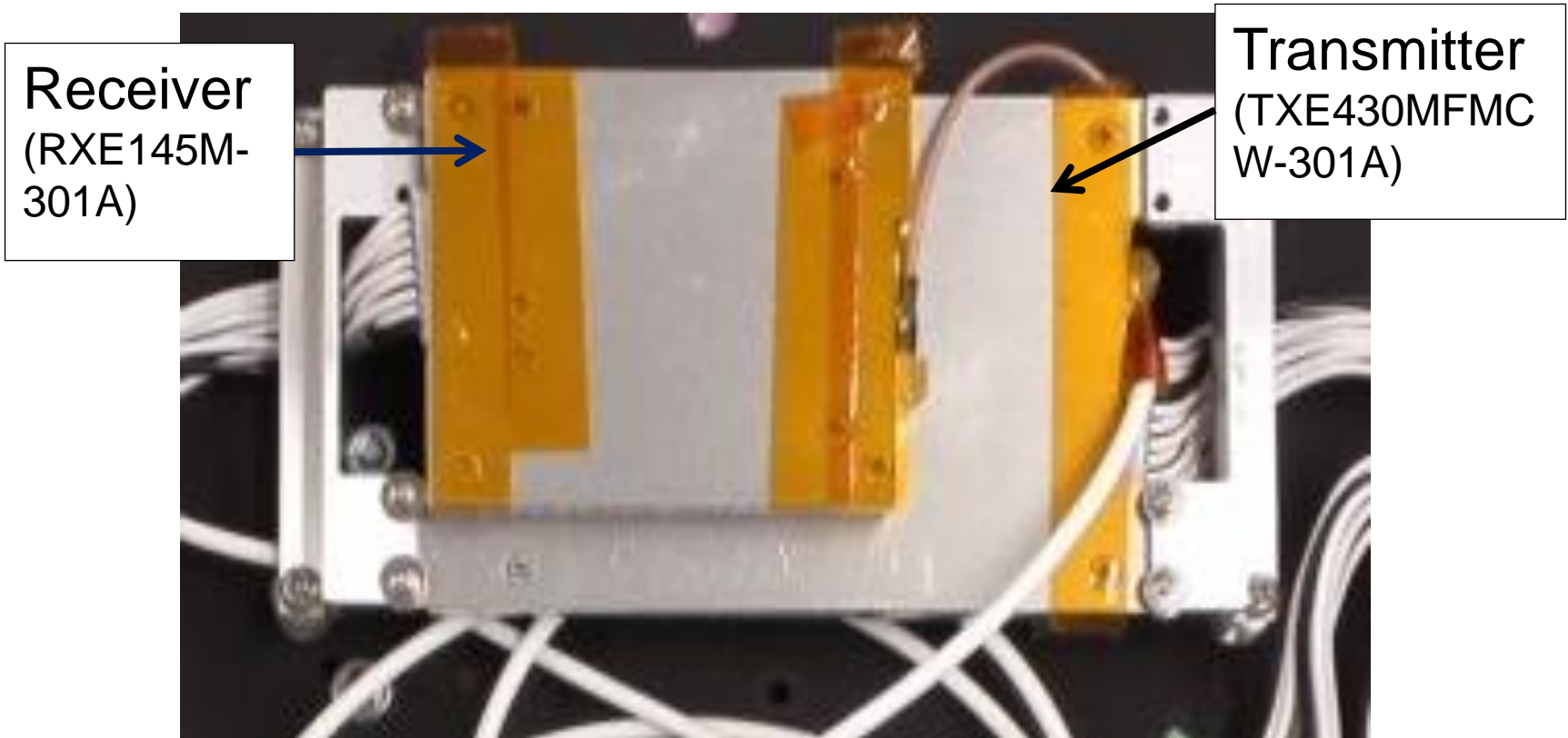

VHF/UHF Communication Controller SATCOM (AXELSPACE, Inc.)

FM Receiver
Connector

FMCW Transmitter
Connector

Connector of
Input Sensor
to A/D
Convertor

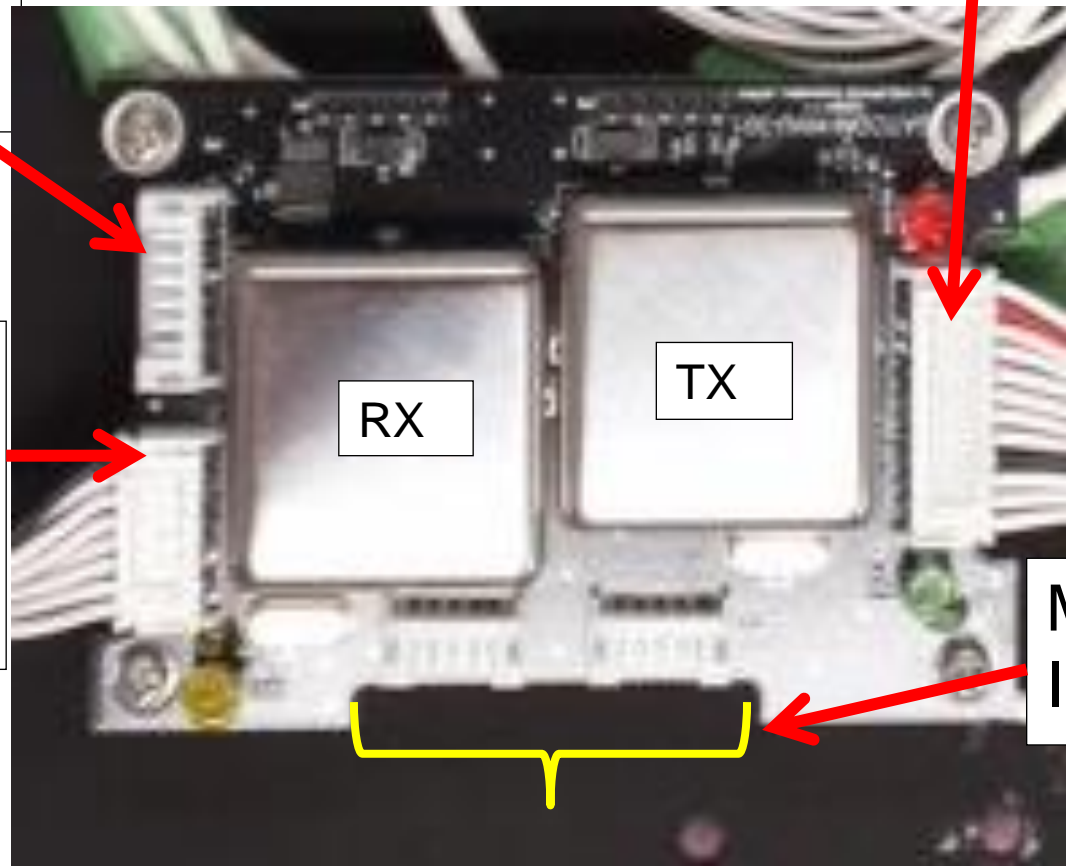

Main OBC
Interface

Specification of SATCOM

Properties	Specification
Dimension [mm]	90×60×15
Mass [g]	42
Operational Voltage [V]	5
Consumption Current [mA]	Receiving : Under 5 (Unconnected with receiver) Under 25 (Connected with receiver) Transmitting: Under 10 (Unconnected with transmitter) Under 650 (Connected with transmitter)
Morse Velocity	Variable in 9 stages
Morse Beacon Analog Data	8-bit、7ch + Receiver RSSI
Modulation System (Packet)	AFSK-FM 1200bps
Modem Output (Transmitter) [Vp-p]	0.85
Packet Protocol	Ax.25 UI-Frame
Maximum Packet Data Length [Bytes]	170
Communication with User CPU	19200bps、Data length 8bit Stop bit 1bit、Without parity

Deployable Monopole Antenna

STM (Structural, Thermal Model)

Antenna material : Ribbon Steel (145.9MHz, Length 537mm)

Electrical characteristics

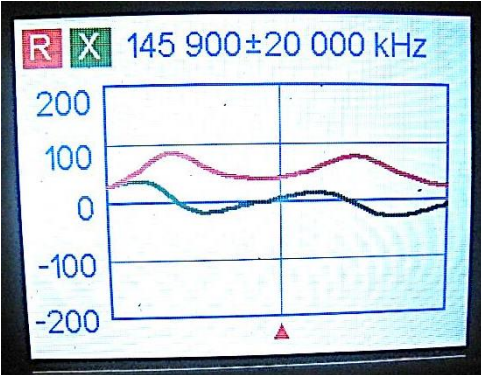
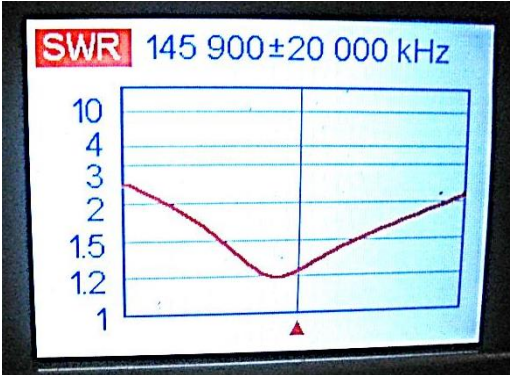

カーソル位置のデータ

145 900 kHz	SWR: 1.26
RL: 18.8 dB	Z : 45.0 Ω
R: 44.1 Ω	X: 9.1 Ω
L: 9.9 nH	
RII: 46.0 Ω	XII: 223.3 Ω
LII: 243.8 nH	

続けるには他のキーを押す

Antenna pattern

X-axis

- (Red: Same polarization)
- (Blue: Cross polarization)

Gain

-1.02 dBi
(4.11 dBi at height 3.2 m)

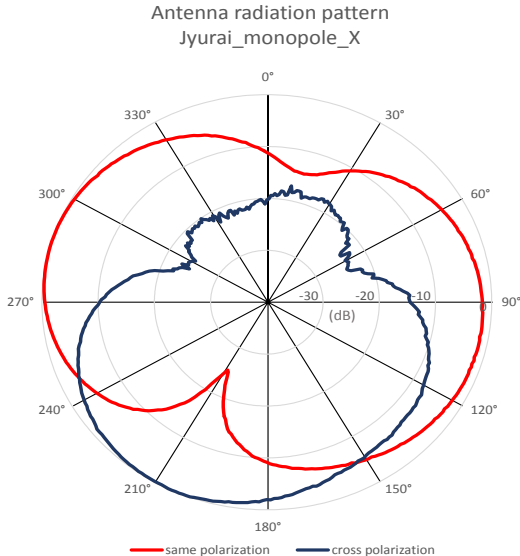

Same Polarization (Horizontal / Horizontal)

Maximum Intensity 61.2dB_{dp} (285 deg)

Cross Polarization (Vertical / Horizontal),

Maximum Intensity 52.29dB_{dp} (206 deg)

Deployable Monopole Antenna

STM (Structural, Thermal Model)

Antenna material : Phosphor Bronze (145.9MHz, Length 532mm)

Electrical characteristics

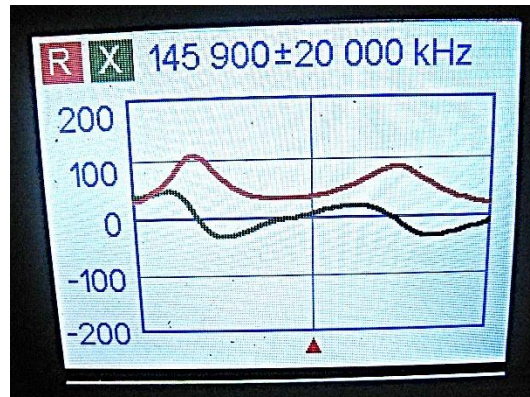

カーソル位置のデータ

145 900 kHz	SWR: 1.43
RL: 15.0 dB	Z : 40.6 Ω
R: 38.9 Ω	X: 11.4 Ω
L: 12.4 nH	
RII: 42.3 Ω	XII: 144.4 Ω
LII: 157.6 nH	

続けるには他のキーを押す

Antenna pattern

X-axis
 (Red: Same polarization)
 (Blue: Cross polarization)

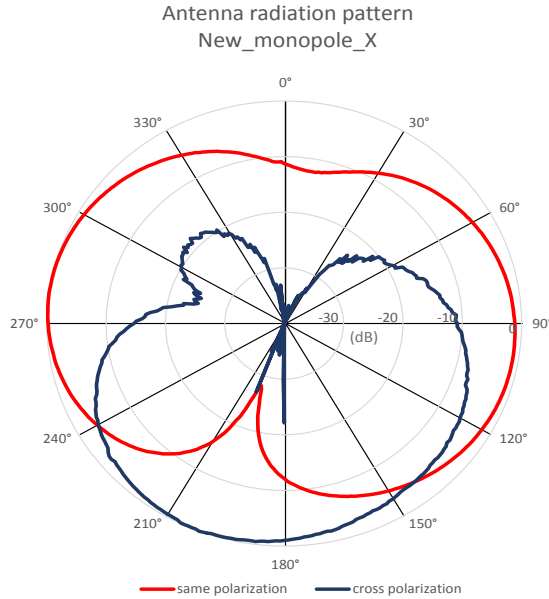

Same Polarization (Horizontal / Horizontal)
 Maximum Intensity 61.17dB_{dp} (278 deg)
 Cross Polarization (Horizontal / Vertical)
 Maximum Intensity 51.91dB_{dp} (201 deg)

Gain

-1.05dBi

Deployable Dipole Antenna

STM (Structural, Thermal Model)

Antenna material : Ribbon Steel (437MHz, Outer length 197mm, Inner length 122mm)

Electrical characteristics

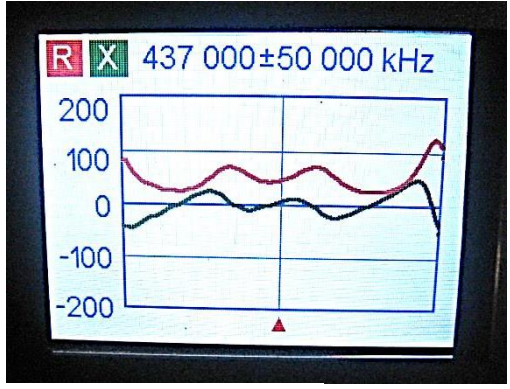
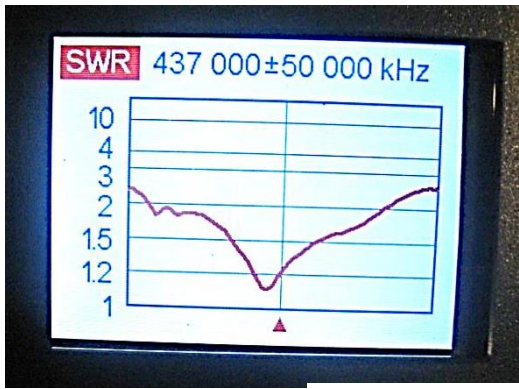

カーソル位置のデータ

437 000 kHz	SWR: 1.27
RL: 18.5 dB	IZI: 52.0 Ω
R: 50.6 Ω	X: 12.0 Ω
L: 4.4 nH	
RII: 53.4 Ω	XII: 225.5 Ω
LI: 82.2 nH	

続けるには他のキーを押す

Antenna pattern

Y-axis
 (Red: Same polarization)
 Blue: Cross polarization

Gain

-0.41 dBi
 (1.01 dBi at height 3.77 m)

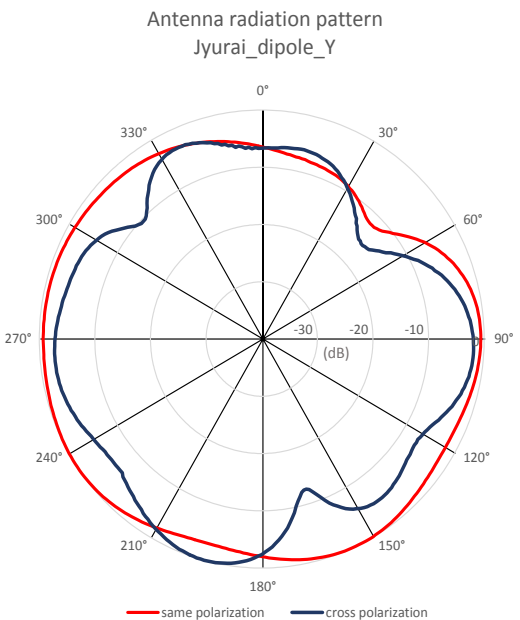

Same Polarization (Horizontal / Horizontal), Height 3.77m
 Maximum Intensity 50.5dB_{dp} (18 deg)
 Cross Polarization (Horizontal / Vertical)
 Maximum Intensity 43.99dB_{dp} (194 deg)

Deployable Dipole Antenna

STM (Structural, Thermal Model)

Antenna material : Phosphor Bronze (437MHz, Outer length 196mm, Inner length 118mm)

Electrical characteristics

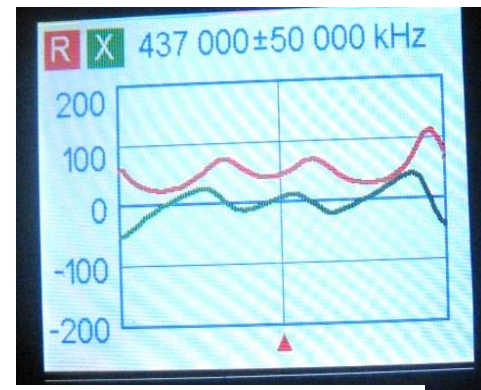
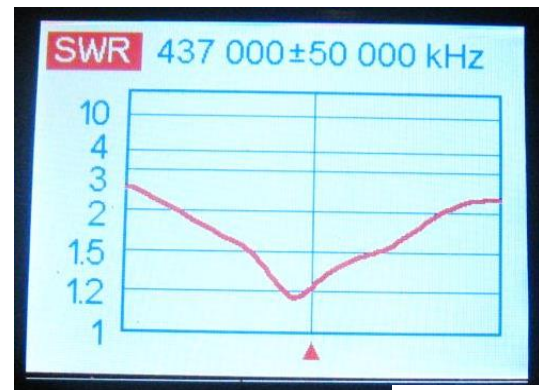

カーソル位置のデータ

437 000 kHz	SWR: 1.26
RL: 18.7 dB	Z : 49.4 Ω
R: 48.1 Ω	X: 11.3 Ω
L: 4.1 nH	
RII: 50.7 Ω	XII: 216.2 Ω
LII: 78.8 nH	

続けるには他のキーを押す

Antenna pattern

(Red: Same polarization)
 (Blue: Cross polarization)

Gain

-0.64dBi

Antenna radiation pattern
New_dipole_X

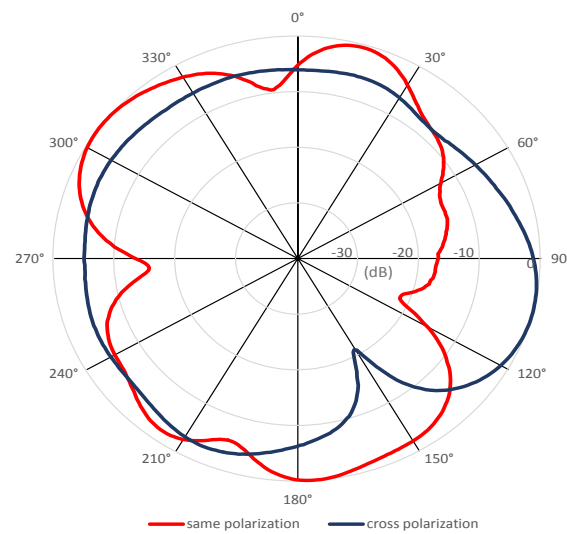

Same Polarization (Horizontal / Horizontal)

Maximum Intensity 48.85dB_{dp}
(229 deg)

Cross Polarization (Horizontal / Vertical)

Maximum Intensity 49.74dB_{dp}
(155 deg)

Non-deployable Inverted L Antenna

STM (Structural, Thermal Model)

Antenna material : **Copper** (145.9MHz, Length 517.5mm)

Electrical characteristics

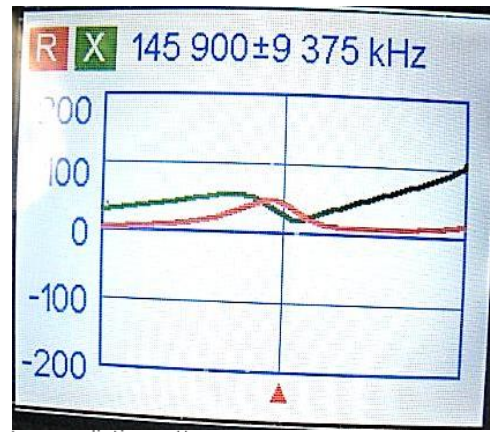
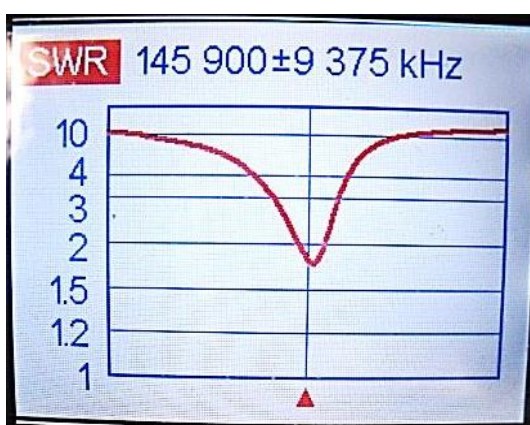

全項目表示	
145 900 kHz	SWR: 1.6
RL: 12.8 dB	Z: 44.4 Ω
R: 40.3 Ω	X: 18.8 Ω
L: 20.5 nH	
RII: 49.0 Ω	XII: 105.2 Ω
LII: 114.8 nH	

Antenna radiation pattern
逆L-145.9MHz_Z

Antenna pattern

Z-axis

(Red: Same polarization)

Blue: Cross polarization)

Gain

-3.47 dBi

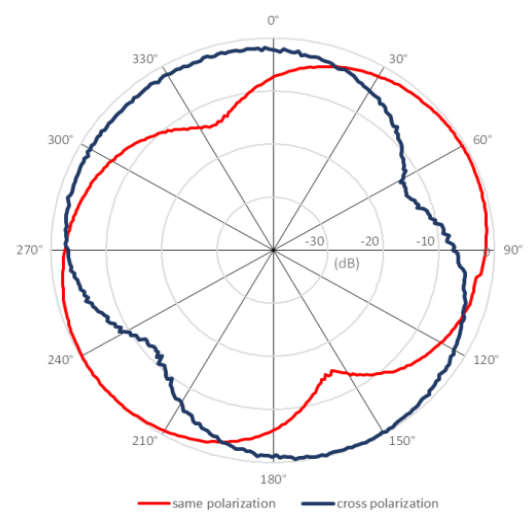

Same Polarization (Horizontal / Horizontal), Height 3.2m

Maximum Intensity 59.59dB_{dp} (150 deg)

Cross Polarization (Vertical / Horizontal),

Maximum Intensity 53.99dB_{dp} (256 deg)

Non-deployable Inverted F Antenna

Bronze (437.0MHz, Length 152mm)

Electrical characteristics

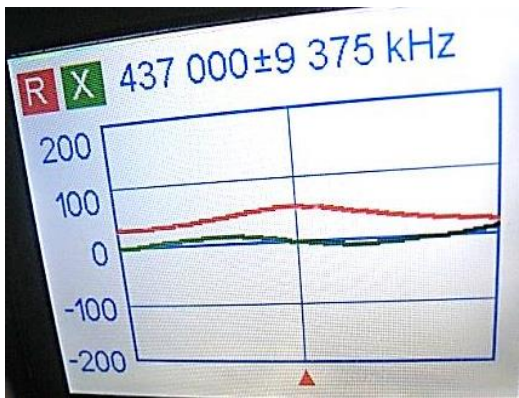
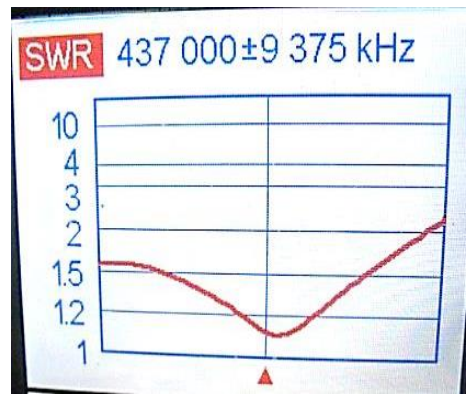

Antenna pattern

Z-axis

(Red: Same polarization)

(Blue: Cross polarization)

Gain

-0.12 dBi

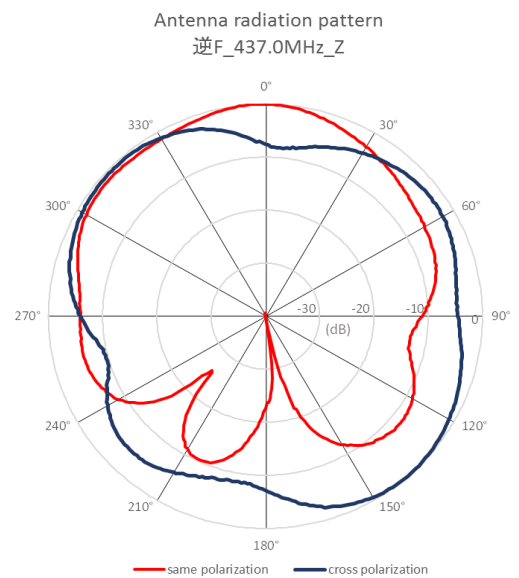

Same Polarization (Horizontal / Horizontal)

Maximum Intensity 50.53dB_{dp} (358 deg)

Cross Polarization (Vertical / Horizontal),

Maximum Intensity 48.0dB_{dp} (139 deg)

TeikyoSat-4 EM (Engineering Model) Antennas

(February, 2017)

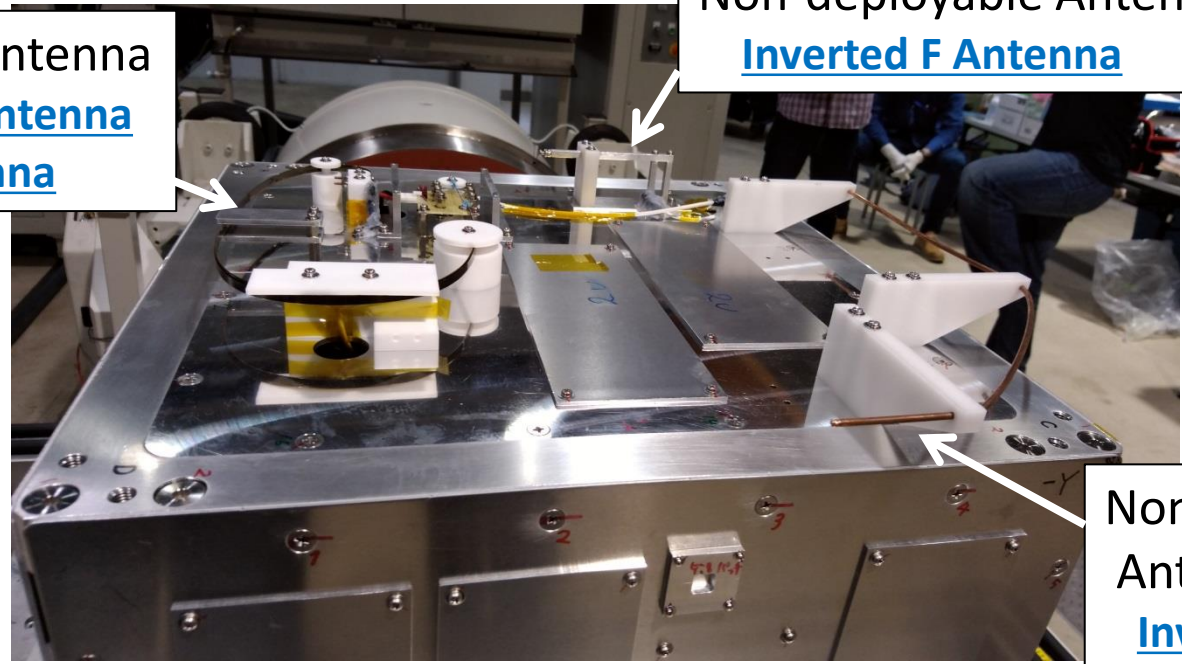

Deployable Antenna
Monopole Antenna
Dipole Antenna

Non-deployable Antenna
Inverted F Antenna

Non-deployable Antenna
Inverted L Antenna

TeikyoSat-4 EM Antennas						
Antenna	Frequency	Length	SWR	R	X	Z
	MHz	mm		Ω	Ω	Ω
Monopole	145.9	544	1.09	49.9	4.2	50
Dipole	437	Outer 195, Inner 118	1.27	54.9	11.4	56.1
Inverted L	145.9	520, Stab 248	1.7	36.8	-20.1	41.9
Inverted F	437	100 + Bolt 10	1.6	31.6	-6.8	32.3

New Mission (High Speed Communication System)

1.26 GHz Receiver

(Logical Products, Inc.)

1.26GHz Receiver



Properties	Specification
Article number	LP-RX1200-SAT1
Frequency	1.26GHz Band
Receiver construction	Triple super heterodyne
First intermediate frequency	320MHz
Second intermediate frequency	21.4MHz
Third intermediate frequency	50kHz
Modulation system	FM (F3E)
Data demodulation system	DTMF
Reception sensitivity	-4dBμV emf
Antenna	Patch antenna
Supply voltage	5V (Reduce to 3.3V internally)
Consumption current	Approx. 40 mA
Substrate size	81×50 mm

5.84 GHz Transmitter

(Logical Products, Inc.)

5.84GHz Transmitter

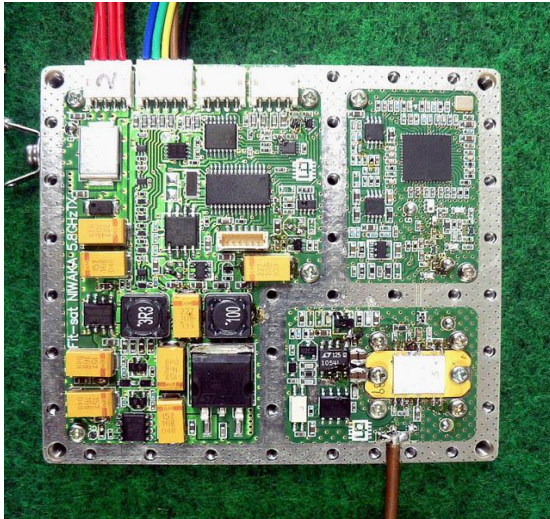

Aluminum casing

Properties	Specification
Article number	LPTX5840-1
Frequency	5.83GHz - 5.84GHz
Terminal high frequency output	Max 2.0W (33dBm)
Supply voltage range	10.3 V - 12.5 V
Supply voltage / consumption current	Approx. 1.45 A (out 2.0W at 11.0V)
Modulation system	2 value - FSK
Modulation frequency range	0 – 120 kbps
Frequency shift	Fp-p = 110 kHz
Antenna	Patch antenna
Substrate size	70(D) x 76(W) x 16(H) mm
Mass	220 g

1.2 GHz Patch Antenna

(Logical Products, Inc.)

Antenna Upper View

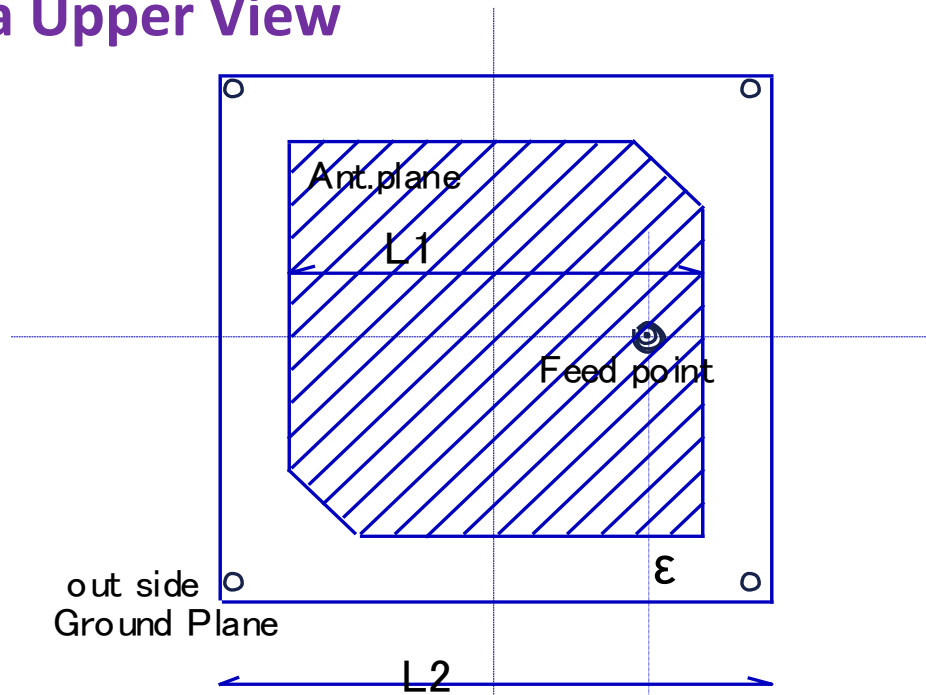

Cross Section

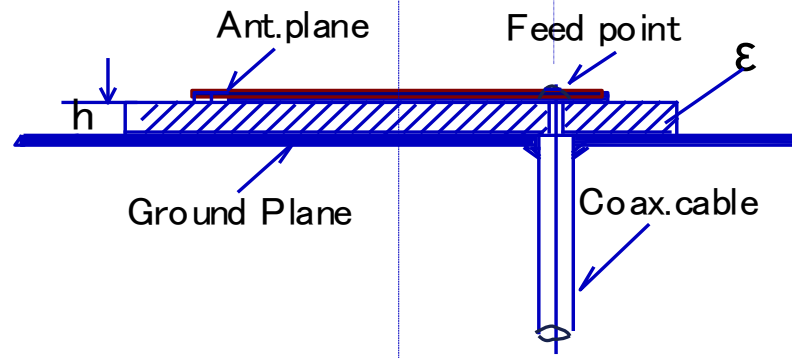

5.84 GHz Patch Antenna (Logical Products, Inc.)

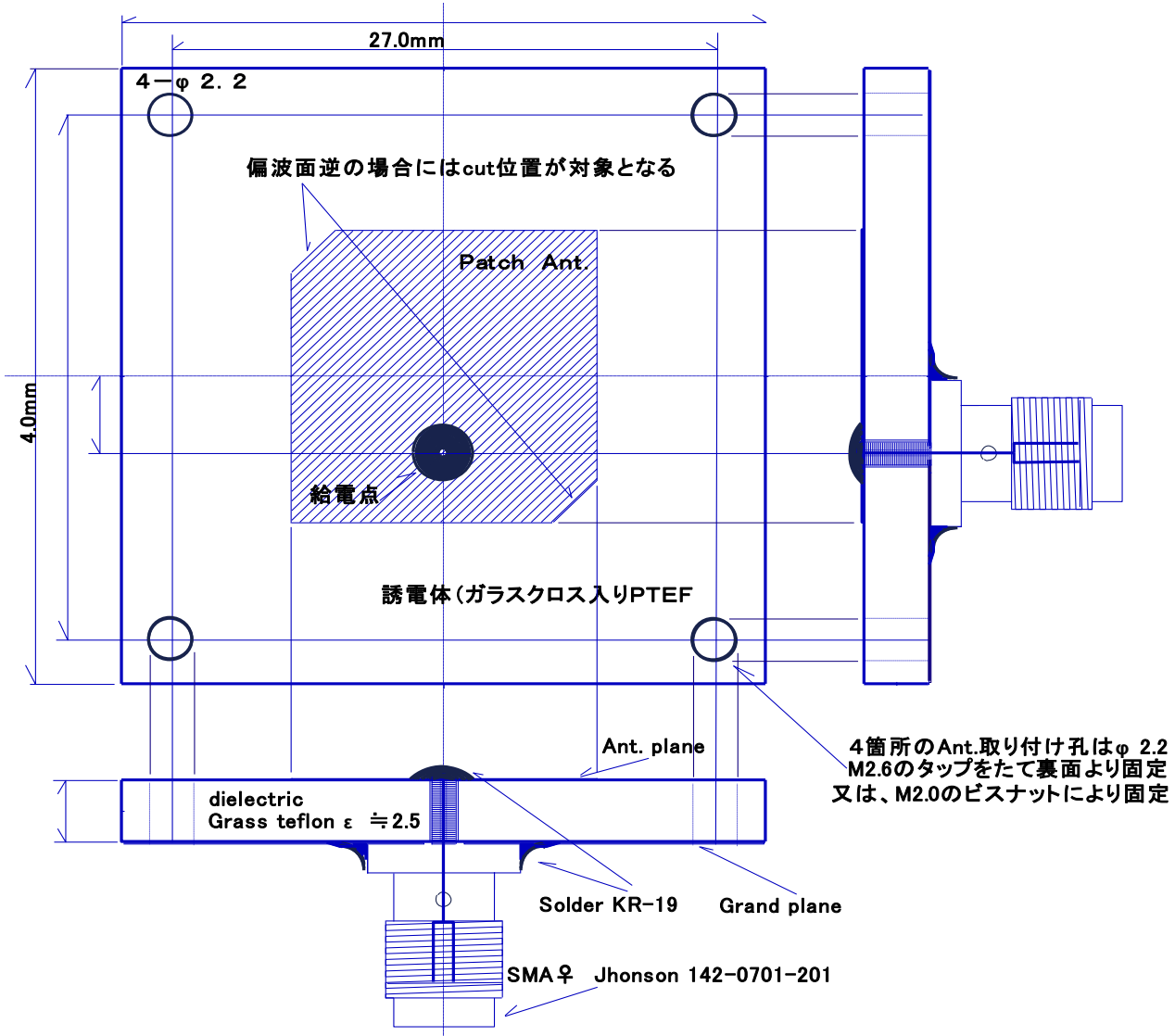

TeikyoSat-4 Antenna Pattern

5.84 GHz Patch Antenna

(measured by Fukuoka Institute of Technology)

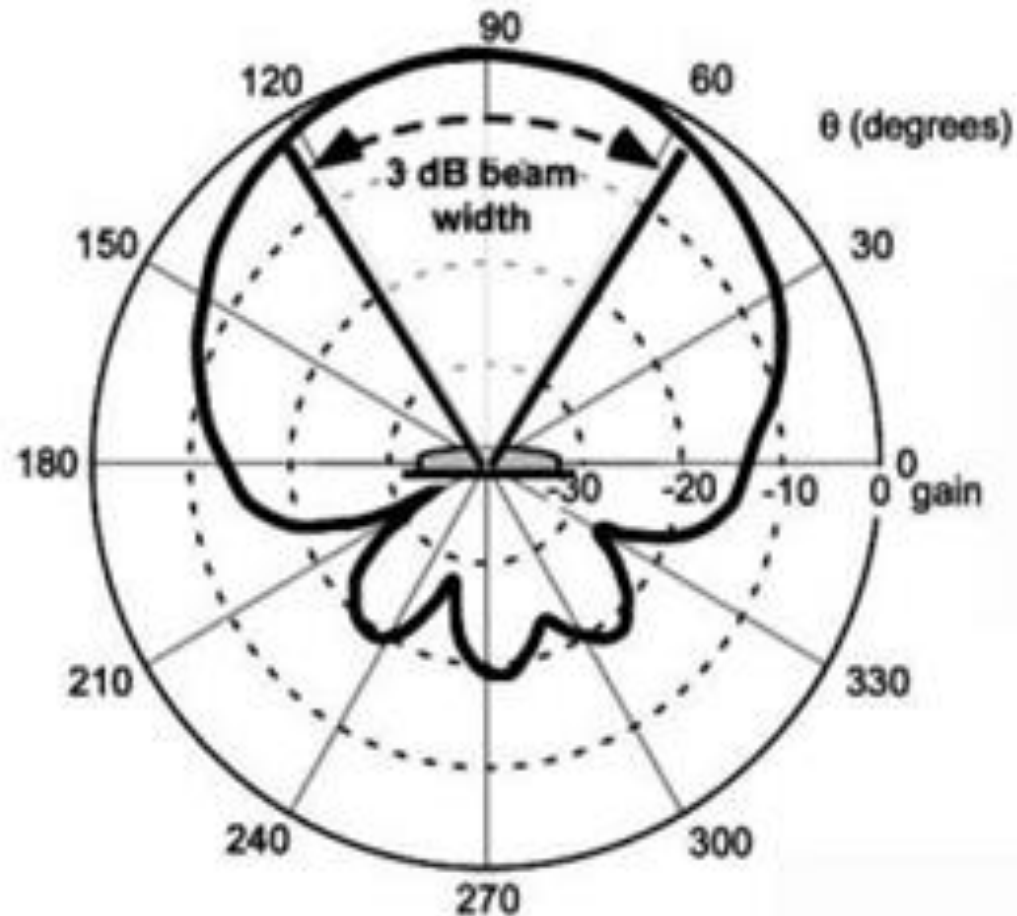

Earth Station for Main Mission

Earth Station Apparatus for TeikyoSat-4 VHF/UHF Communication (1)

Transmitter / Receiver

Main ICOM IC-9100M (Back up: ICOM IC-911D)

Antenna

for 144 MHz (TX) : JACOM CY144-211 (2*11)

for 430 MHz (RX) : JACOM CY430-219 (2*19)

Pre-amp (LNA)

Kawagoe Musen 430MHzStandard

Antenna Rotator

Azimuth /Elevation Combination YAESU G5500

Earth Station Apparatus for TeikyoSat-4 VHF/UHF Communication (2)

○Upper Shelf

- Stabilized Power Source

Daiichi Denpa Kogyo GSV-3000

- VHF/UHF Transmitter/Receiver (Back up)

ICOM IC-911D

○Middle Shelf

- Controller for Azimuth/Elevation Rotator

(Replace for YSESU G5500)

○Lower Shelf

- SWR/Power meter DAIWA CN-801SII

- VHF/UHF Transmitter / Receiver

ICOM IC- 9100M

- Power Source for Transmitter/Receiver

ICOM PS-126



TeikyoSat-4 Earth Station System Diagram (VHF/UHF)

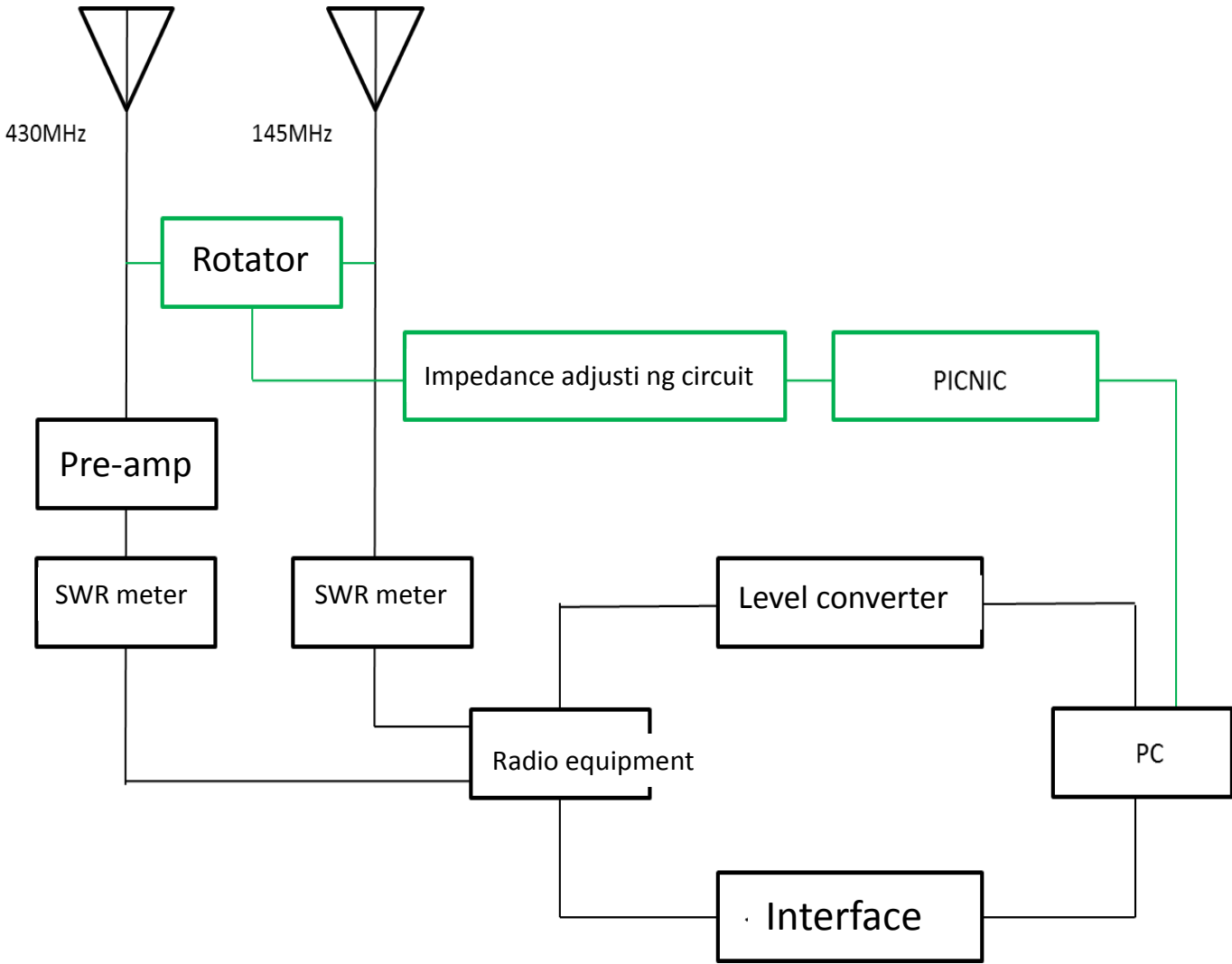

TeikyoSat-4 Earth Station Antenna (VHF/UHF)

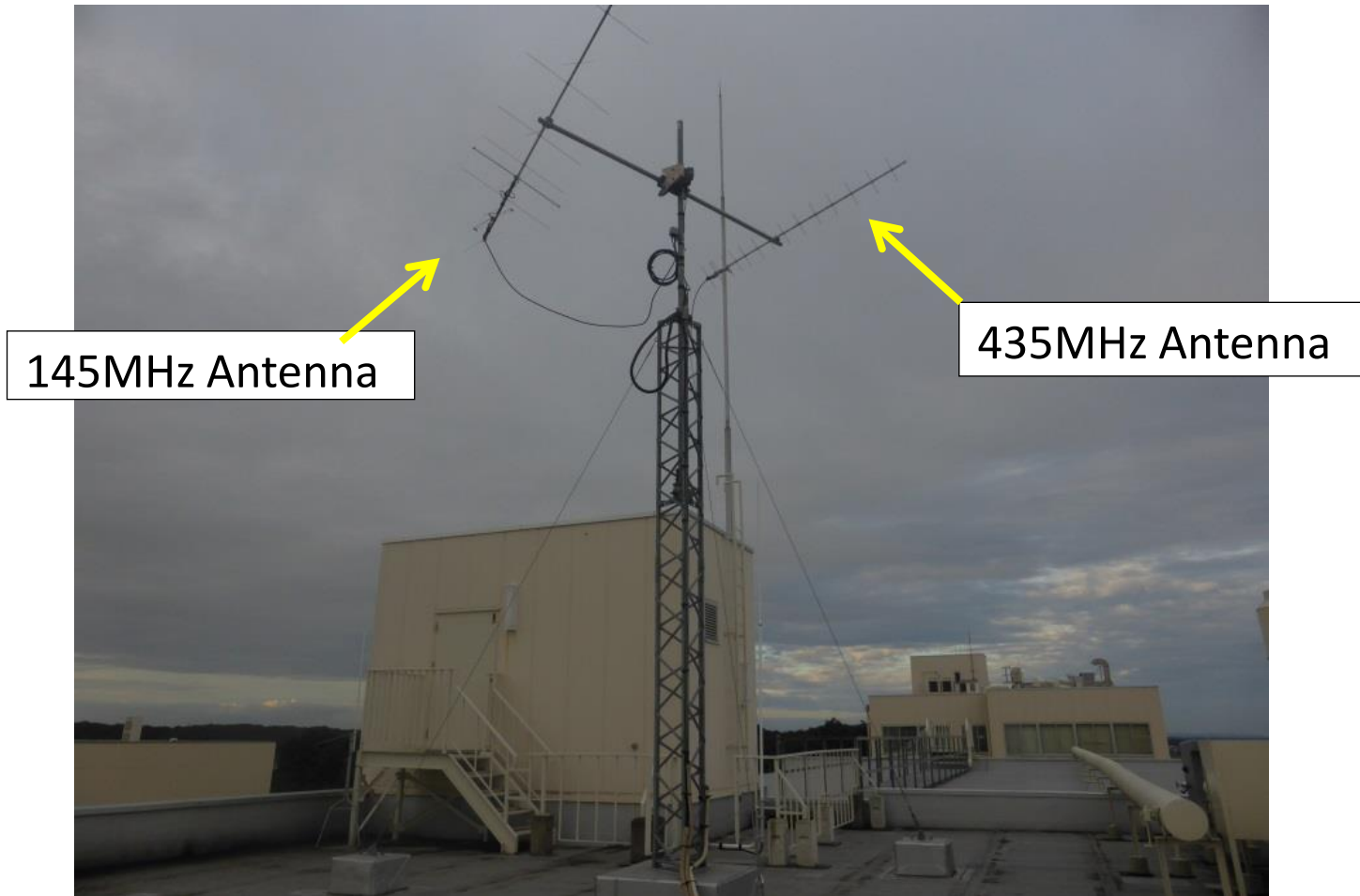

Earth Station for New Mission

System Diagram of Earth Station for High-Speed Communication

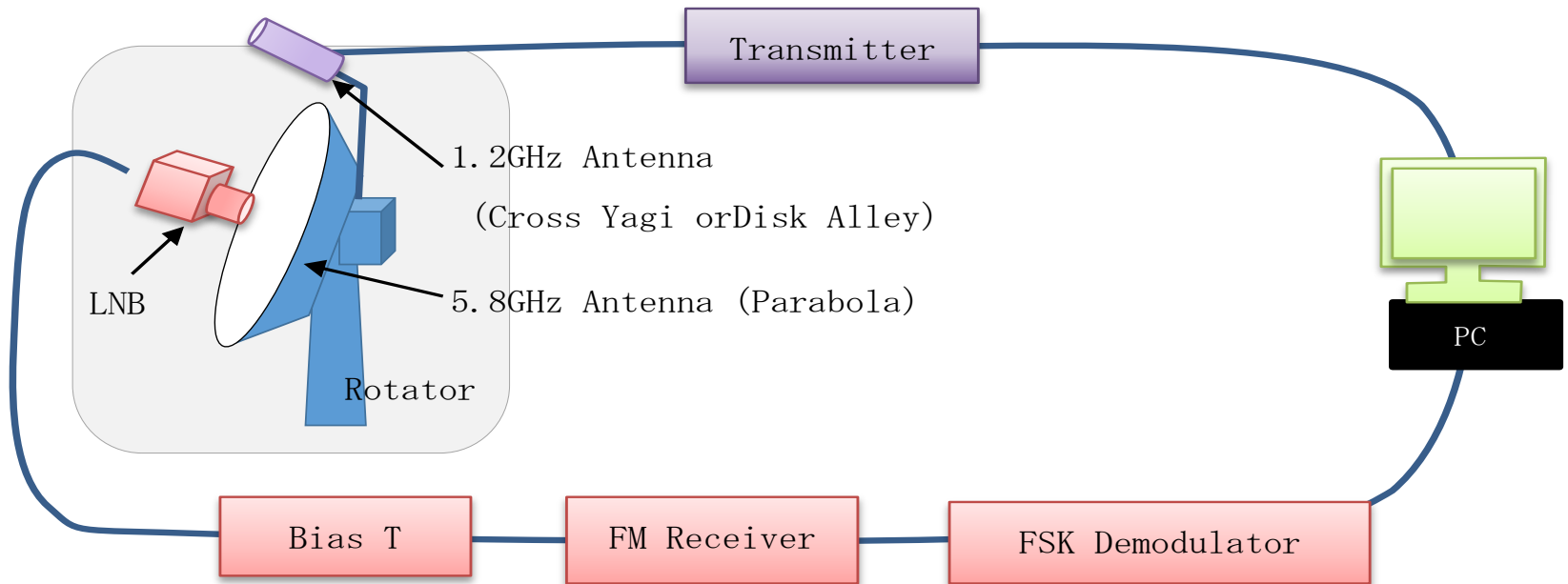

Planned Antenna for TeikyoSat-4 High-Speed Communication System

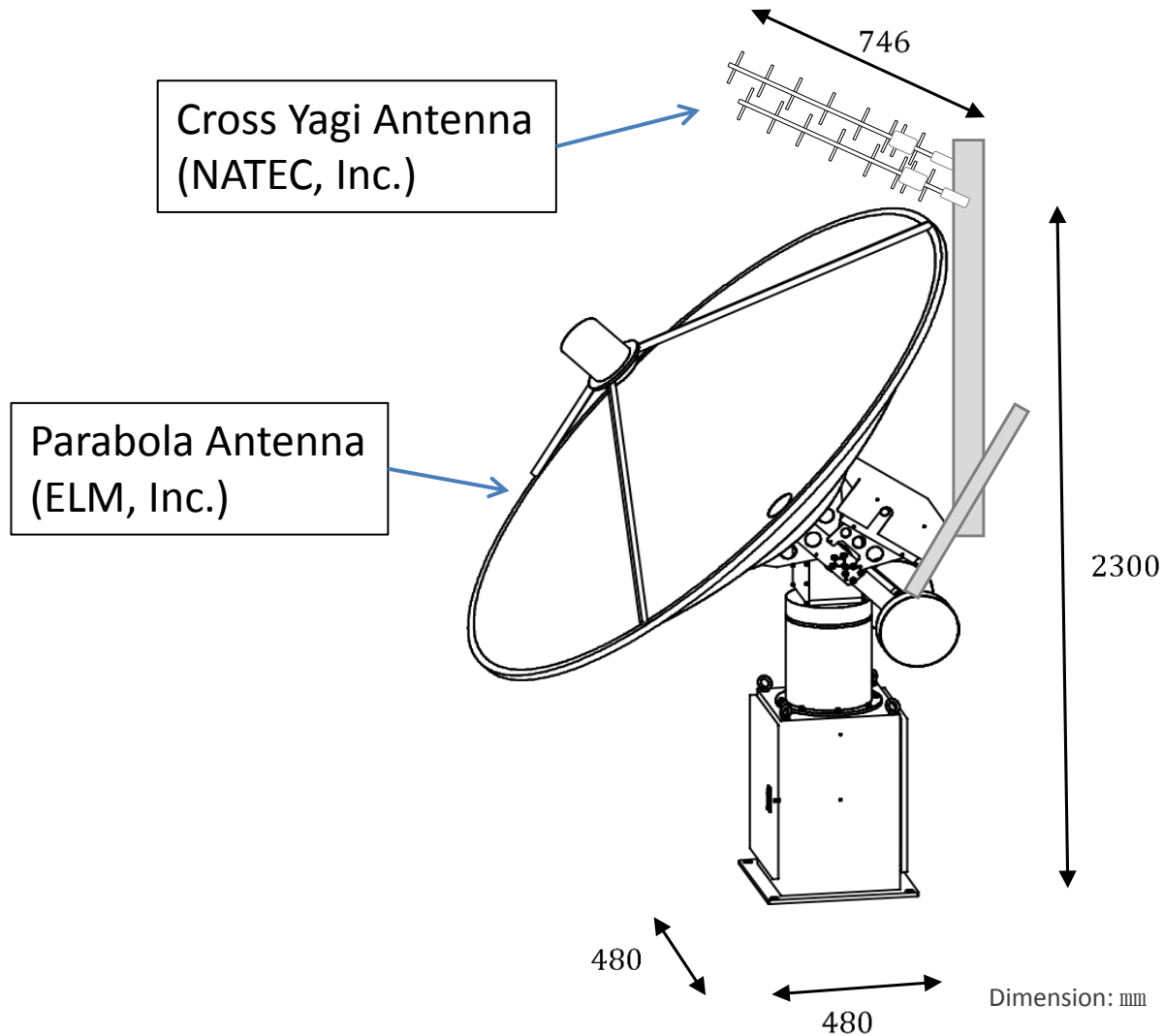

Link Budget

Link Budget for VHF/UHF Deployable Antenna

(Uplink: 145 MHz, Downlink: 435 MHz)



145/435MHz	Monopole	AFSK	Dipole	CW Beacon
Frequency	145.9MHz	437.0MHz	437.0MHz	437.5MHz
Orbital altitude	600.0km	600.0km	600.0km	600.0km
Maximum slant range (Elevation 15°)	1626.2km	1626.2km	1626.2km	1175.5km
Transmitter				
Transmission output	50.0W	0.8W	0.8W	0.1W
Transmission power	17.0dBw	-1.0dBw	-1.0dBw	-10.0dBw
Transmitting feed loss	1.0dB	1.0dB	1.0dB	2.2dB
Transmitting antenna	2×11ele	dipole	dipole	dipole
Transmitting antenna gain	17.1dBi	1.0dBi	1.0dBi	1.0dBi
Transmitter antenna pointing loss	1.5dB	2.0dB	2.075°	5.975°
Equivalent isotopically radiated power	16.0dBw	-2.0dBw	-2.0dBw	-12.2dBw
Free space loss	140.0dB	149.5dB	149.5dB	146.7dB
Polarization loss	(3.0)dB	(3.0)dB	(3.0)dB	(3.0)dB
Receiver				
Receiving antenna	monopole	2×19ele	2×19ele	15ele×2
Receiving antenna gain	4.1dBi	19.2dBi	19.2dBi	19.2dBi
Receiver antenna pointing loss	0.0dB	2.5dB	2.5dB	2.5dB
Modulation method	AFSK/FM	AFSK/FM	GMSK	CW
Bit-rate	1200.0bps	1200.0bps	9600.0bps	
Threshold	21.0dB	21.0dB	9.6dB	10.0dB
System link margin	43.6dB	17.3dB	19.7dB	----
S/N link margin	39.3dB	24.8dB	24.8dB	22.5dB

Link Budget for VHF/UHF Non-deployable Antenna

(Uplink: 145 MHz, Downlink: 435 MHz)



145/435MHz	Inverted L antenna		Inverted F antenna	
		AFSK	GMSK	CW Beacon
Frequency	145.9MHz	437.0MHz	437.0MHz	437.5MHz
Orbital altitude	600.0km	600.0km	600.0km	600.0km
Maximum slant range (Elevation 15°)	1626.2km	1626.2km	1626.2km	1175.5km
Transmitter				
Transmission output	50.0W	0.8W	0.8W	0.1W
Transmission power	17.0dBW	-1.0dBW	-1.0dBW	-10.0dBW
Transmitting feed loss	1.0dB	1.0dB	1.0dB	2.2dB
Transmitting antenna	2×11ele	Inverted F antenna	Inverted F antenna	Inverted F antenna
Transmitting antenna gain	17.1dBi	-0.12dBi	-0.12dBi	-0.12dBi
Transmitter antenna pointing loss	1.5dB	0.0dB	0.075°	0.075°
Equivalent isotropically radiated power	16.0dBW	-2.0dBW	-2.0dBW	-12.2dBW
Free space loss	140.0dB	149.5dB	149.5dB	146.7dB
Polarization loss	(3.0)dB	(3.0)dB	(3.0)dB	(3.0)dB
receiver				
Receiving antenna	Inverted L antenna	2×19ele	2×19ele	15ele×2
Receiving antenna gain	-3.5dBi	19.2dBi	19.2dBi	19.2dBi
Receiver antenna pointing loss	0.0dB	2.5dB	2.5dB	2.5dB
Modulation method	AFSK/FM	AFSK/FM	GMSK	CW
Bit-rate	1200.0bps	1200.0bps	9600.0bps	
Threshold	21.0dB	21.0dB	9.6dB	10.0dB
System link margin	36.0dB	18.2dB	20.6dB	---
S/N link margin	31.7dB	25.7dB	25.7dB	27.3dB

Link Budget for High-Speed Communication System

(Uplink: 1.2 GHz, Downlink: 5.8 GHz)



1265/5840MHz		Φ1.8m Parabolic antenna	Φ2.0m Parabolic antenna
Frequency	1200.0MHz	5800.0MHz	5800.0MHz
Orbital altitude	600.0km	600.0km	600.0km
Maximum slant range (Elevation 30°)	1075.19km	1075.19km	1075.19km
Transmitter			
Transmitting antenna	10.00W	2.00W	2.00W
Transmission power	10.0dBw	3.01dBw	3.01dBw
Transmitting feed loss	1.32dB	0.17dB	0.17dB
Transmitting antenna	Cross Yagi	Patch antenna	Patch antenna
Transmitting antenna gain	12.00dBi	6.00dBi	6.00dBi
Transmitter antenna pointing loss	0.110.1°	5.1dB 57°	5.1dB 57°
Equivalent isotopically radiated power	18.39dBw	8.50dBw	8.50dBw
Free space loss	154.68dB	168.36dB	168.36dB
Polarization loss	0.00dB	0.00dB	0.00dB
receiver			
Receiving antenna	Patch antenna	Parabolic antenna φ1.8	Parabolic antenna φ2.0
Receiving antenna gain	6.0dBi	37.7dBi	38.8dBi
Receiver antenna pointing loss	5.10.1°	2.98dB 5°	3.74dB 5°
Modulation method	AFSK/FM 1k2	FSK 115k2	FSK 115k2
Signal pass band width	20,000Hz	280,000Hz	280,000Hz
Threshold	22.00dB	21.00dB	21.00dB
Transmitter antenna pointing loss	12.96dB	9.05dB	9.38dB
S/N link margin	8.34dB	9.59dB	9.93dB
LNA		18dB	18dB

Telemetry Formats (CW)



The followings are telemetry formats with SATCOM in the case of TeikyoSat-3.

Telemetry formats for TeikyoSat-4 shall be formulated along those for TeikyoSat-3 (TBD).

Morse default message

(call sign)_(Call sign)_(call sign)_: _TS3_TS3

S1_(RSSI)_(AD1)_(AD2)_(AD3)

S2_(AD4)_(AD5)_(AD6)_(AD7)

where RSSI, AD1-7 are A/D converted data of hexadecimal digits of 2 bite.

Element	Property	Equation
RSSI	Receiving Intensity [V]	(Analog)/1000
AD1	Temperature of Access Panel-Y [deg C]	$0.000004(\text{Analog})^2 - 0.0447(\text{Analog}) + 111.82$
AD2	Temperature of Access Panel-Z [deg C]	$0.000004(\text{Analog})^2 - 0.0456(\text{Analog}) + 112.41$
AD3	Temperature of Access Panel+Y[deg C]	$0.000004(\text{Analog})^2 - 0.0444\text{Analog} + 112.24$
AD4	Temperature of Access Panel+Z [deg C]	$0.000005(\text{Analog})^2 - 0.0482(\text{Analog}) + 112.61$
AD5	Temperature of Upper Panel [deg C]	$0.000004(\text{Analog})^2 - 0.0453(\text{Analog}) + 111.83$
AD6	Ambient Temperature in Mission Module [deg C]	(Analog)/10
AD7	Pressure in Mission Module [hPa]	$1013.25 - ((179.4594595 - (\text{Analog})/11.1)/0.26)$

(Analog) : Analog voltage data converted from hexadecimal digits of 2 bite